

The Great Awakening

Starting ZR-1's After Years of Sleep

Marc Haibeck

The Great Awakening

Awakening Number One

A '93 after three years.

- 900 miles. Stored in a climate controlled garage.
- It would crank, fire but would not run.
- It had a spark, and normal fuel pressure.
- Suspected stuck fuel injectors.

The Great Awakening

Awakening Number One

- Pulsed the fuel injectors. Six of them did not flow.
- Removed and cleaned the fuel injectors.
- The engine started and idled smoothly.

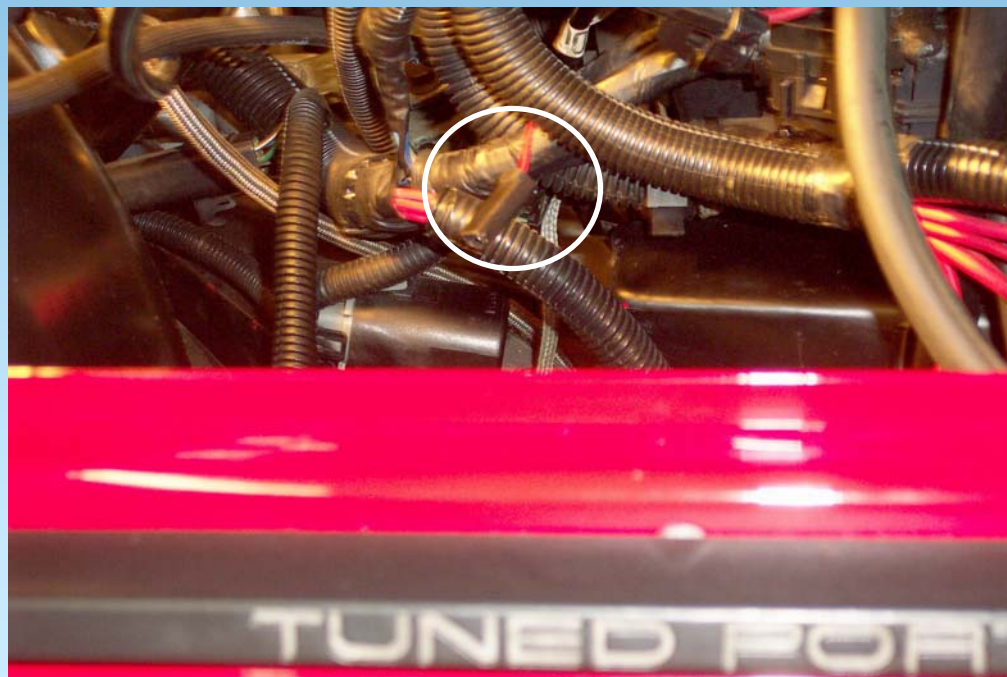
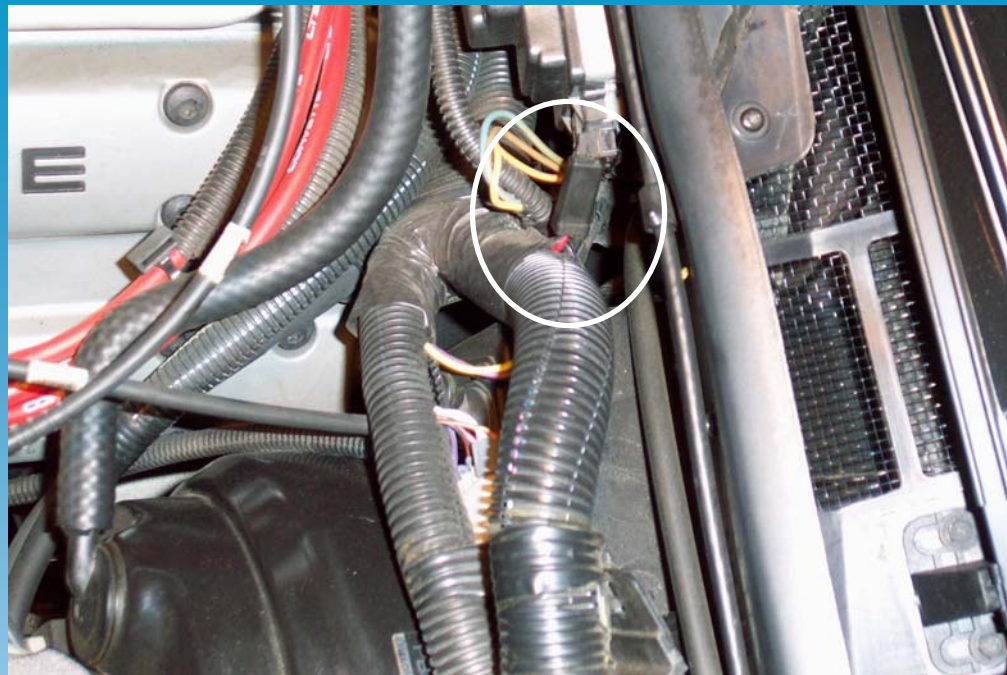

ECM

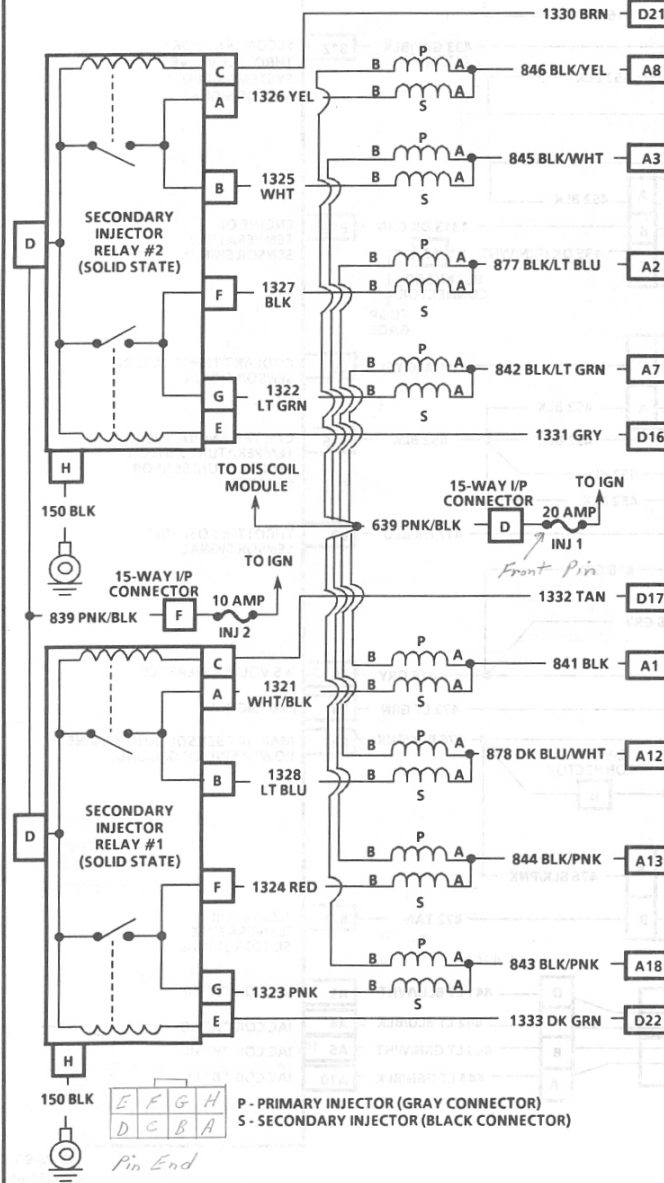

- 1330 BRN [D21] SECONDARY INJECTOR RELAY #2 CONTROL CYL #5 & #6
- 846 BLK/YEL [A8] CYLINDER #6 INJECTOR (S) CONTROL
- 845 BLK/WHT [A3] CYLINDER #5 INJECTOR (S) CONTROL
- 877 BLK/LT BLU [A2] CYLINDER #7 INJECTOR (S) CONTROL
- 842 BLK/LT GRN [A7] CYLINDER #2 INJECTOR (S) CONTROL
- 1331 GRY [D16] SECONDARY INJECTOR RELAY #2 CONTROL CYL #2 & #7
- 639 PNK/BLK [D] TO DIS COIL MODULE
- 1332 TAN [D17] SECONDARY INJECTOR RELAY #1 CONTROL CYL #1 & #8
- 841 BLK [A1] CYLINDER #1 INJECTOR (S) CONTROL
- 878 DK BLU/WHT [A12] CYLINDER #8 INJECTOR (S) CONTROL
- 844 BLK/PNK [A13] CYLINDER #4 INJECTOR (S) CONTROL
- 843 BLK/PNK [A18] CYLINDER #3 INJECTOR (S) CONTROL
- 1333 DK GRN [D22] SECONDARY INJECTOR RELAY #1 CONTROL CYL #3 & #4

150 BLK

E	F	G	H
D	C	B	A

P - PRIMARY INJECTOR (GRAY CONNECTOR)
 S - SECONDARY INJECTOR (BLACK CONNECTOR)

Pin End

The Great Awakening

Awakening Number Two

A '92 with 1000 miles.

- It had not been started for ten years.
- The fuel had no odor. Removed the fuel sender assembly. Removed all of the fuel and wiped the tank clean. Installed a new fuel filter.
- Replaced the obsolete fuel injectors.

The Great Awakening

Awakening Number Two

- Replaced all of the fluids.
- Sprayed about .2 ounce of oil into each cylinder.
- Pressurized the oiling system to 30 psi with three quarts of oil.
- Primed the fuel system.
- The engine started with the noises that a normal engine makes after sitting for a month.

The Great Awakening



The Great Awakening

23 Year Old Tires

- The awakening number two car's tires had huge flat spots that did not get better when driven.
- Tires are date coded. Week/year, ww/y. For example a Gatorback dated 219 = week 21 in 1989.
- Tires over eight years old are dangerous.

The Great Awakening

The Bose Sound System

- The second major restoration expense on a low mileage ZR-1.
- Amplifiers. $\$90 \times 4 = \360 .
- CD player. $\$250$.
- CDM or radio box. $\$435$ installed on '90 – '92 cars. $\$285$ on '93 – '95 cars.
- $360 + 250 + 435 = \$1045$.

The Great Awakening

Miscellaneous Other Items

- Oil cooler hose assembly.
- Clutch slave cylinder.
- Shock absorbers.
- Convert the AC to R134a refrigerant.
- Seat lumbar pumps.
- I have never seen a leaky engine, transmission or axle seal on a low mileage car with many years of storage.

The Great Awakening

Old Fuel

- Fuel seems to store okay for a year.
- Remove two year old fuel and use it in a daily driven vehicle.
- After three years the engine may not fire.
- Always store the car with a full tank.
- I don't see any value in a fuel stabilizer additive.